

Cartessa Corporation DC Output Zero Voltage Monitor

SPECIFICATIONS:

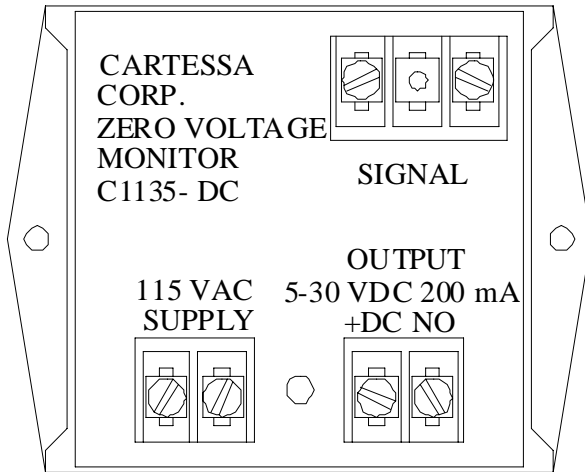

Dimensions: 4 x 3 x 2 in. (10 x 7.5 x 5 cm).

Input Power: 115 VAC $\pm 20\%$, 50/60 Hz.

Signal Threshold: 30mV_{rms}.

Maximum Signal Voltage: 600V_{rms}, 0.015Hz to 4 kHz.

Input Impedance: 100 kohm, minimum.

Transfer Delay: 0.5 to 60 seconds available. Variable or fixed. Standard is 0.75 seconds fixed.

Output Current: 200mA.

Output Voltage: 5-30VDC.

Output Type: Transistor

Operating Temperature: 0°C to 70°C.

Using the Zero Voltage Monitor:

The primary use for the Zero Voltage Monitor is in preventing access to rotating machinery that has not yet come to a complete stop. To accomplish this, connect the Monitor as shown in the wiring diagram below. The signal input will sense the voltage present at the motor terminals. While the motor is rotating, the terminal voltage will be much higher than the 30 mV threshold of the signal input. As the motor slows and comes to a complete stop, the terminal voltage falls below 30 mV. After a predetermined time (the Transfer Delay), the output of the Monitor will close and a red LED will illuminate to alert the operator. When the output closes, the Safety Un-Latch Relay energizes. This relay is used to prevent access to the protected machinery until fully stopped.

To accommodate the needs of different users, the Zero Voltage Monitor can be configured with a variable Transfer Delay. A potentiometer allows the user to set the delay to the appropriate time for different applications. Delays as long as 60 seconds or as short as 0.5 seconds can be selected in this fashion.

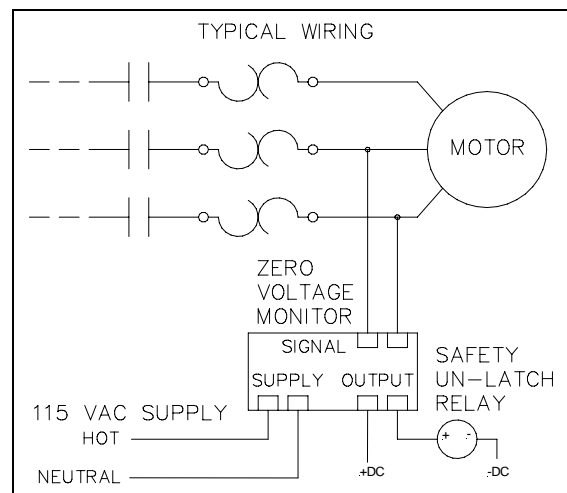

[Back to Main Page](#)