

TARA CONTROLS

AGC-3

A USER'S GUIDE

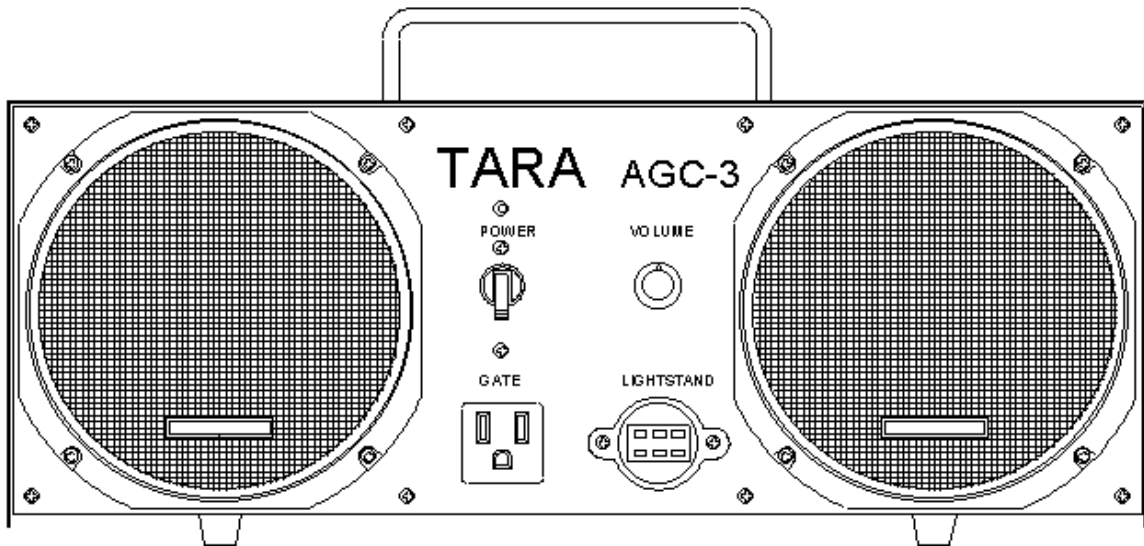

TARA CONTROLS by Cartessa Corporation

4825 Cincinnati-Brookville Road

Shandon, Ohio 45063

Phone: 513-738-4477 Fax: 513-738-4482

1. Component Layout.

The AGC-3 gate controller is an all-in-one unit, complete with built-in speakers and microphone. With a microprocessor controlling all functions, the unit is accurate, flexible and user friendly. The front panel of the enclosure (see Fig.1) contains the following controls and components: (1) Two automotive type speakers

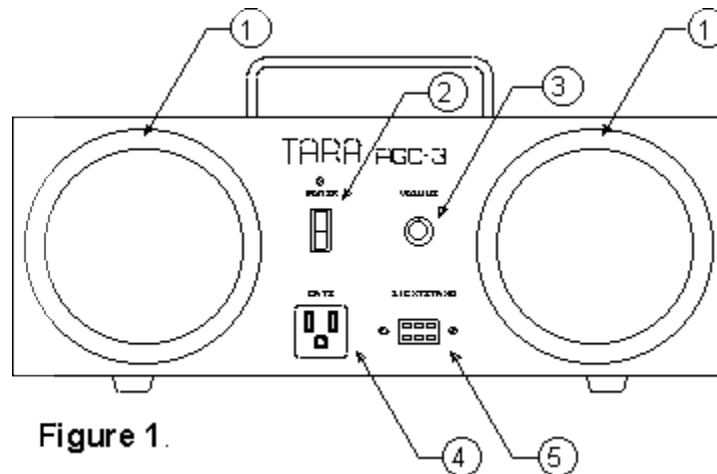

with protective grills. The speakers are normally connected to the internal amplifier as a convenient source for voice and horn. (2) A main power switch with a red power ON light. This switch controls power to the controller including the air gate output. The switch does not control power to the rear panel utility outlet, which is unswitched. (3) A volume control for speaker and external PA amplifier loudness. The volume control has been factory adjusted so that at the maximum (clockwise) setting, there is some distortion on the voice from the built-in speakers. For the best voice quality when using the built-in speakers, set this control to a little less than full volume. (4) An air gate output. This receptacle provides 120 VAC to a user supplied air gate. The operation of this outlet will be described in detail in the Operations section of this manual. (5) A six-pin light stand socket. This outlet will drive an optional 12 VDC TARA lightstand.

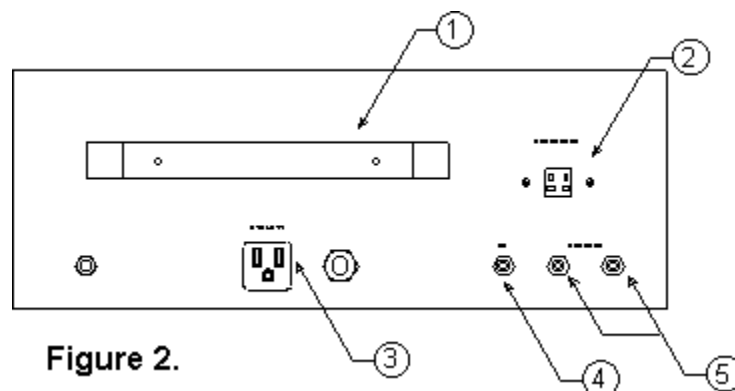

The rear panel of the enclosure (see Fig.2) contains the following controls and components: (1) A cable winding bracket. Use this feature to store the handcontrol cable and the power cord. (2) A four pin accessories outlet. This outlet is typically used to power one or two gate magnets, but can also be used for special functions (refer to the Specifications page of this manual). (3) A 120 VAC utility outlet. This outlet is not switched and will be on as long as the power cord is connected to an energized outlet. (4) One PA amplifier output. This output can be used with an external amplifier. The output level is controlled by the volume control (item 3 in figure 1). (5) Two external speaker outputs. One or both outputs can be used with external speakers. This allows the operator to position the speakers in a different place than the gate controller. When inserting a plug in either jack, the corresponding internal speaker is turned off.

The hand control is connected to the AGC-3 through a 25-foot long cable. The

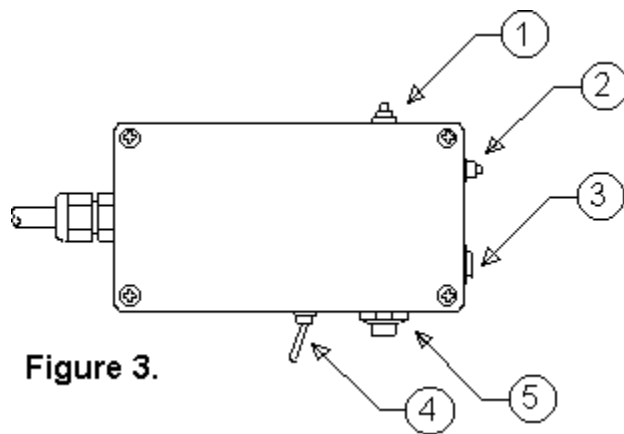

Figure 3.

hand control (see Fig.3) contains the following controls and components: (1) A microphone activation switch. Depressing the switch will turn on the microphone (3). This switch allows the operator to use the microphone without any annoying feedback when moving too close to the AGC-3. For best results, do not depress this switch unless the microphone is used. (2) An air gate reset switch. This switch will raise the gate after the gate has dropped and the riders have moved away. (4) A recall horn switch. This switch will activate an electronic horn for rider recalls. (5) A start switch. This switch will start the gate controller and step through the voice commands and the lights/horn sequence.

2. Operation.

2.1. Initial Settings.

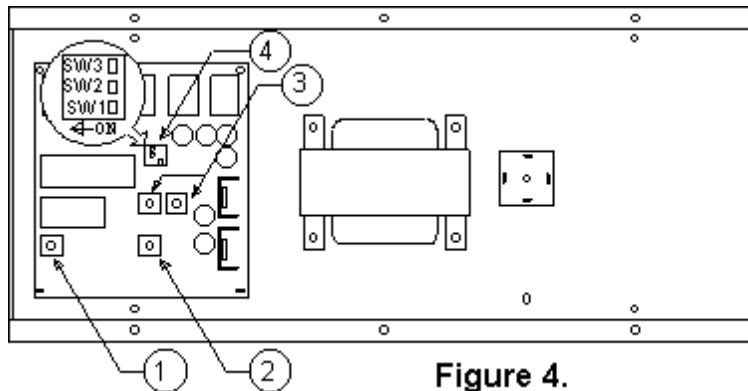

Figure 4.

The AGC-3 controller has a few internal adjustments. To gain access to these controls, **unplug the power cable**, and then remove the top of the AGC-3. If changes to the factory settings are necessary there are two potentiometers, two rotary switches and one three position switch (see Fig. 4). The volume control (1) is used to adjust the loudness of the recall horn relative to the voice. Turning the potentiometer clockwise will increase the loudness of the horn. The tone control (2) changes the pitch (frequency) of the electronic horn. Turning the potentiometer clockwise will increase the pitch. The two rotary switches (3) affect the timing of the voice commands. These switches have been factory set according to league standards and should not be changed without consulting with league officials. On the three position switch (4), SW1 and SW2 controls the mode of the microprocessor, and should not be changed without consulting the factory. SW3 controls the operation of the Gate outlet (item 4 in figure 1). When this switch is in the off position, the gate used must have up/down capability (no magnets used to hold and drop the gate). If magnets are used and the gate only has air assist when being raised, SW3 should be in the on position.

2.2 Field set up.

1. Position the AGC-3 where the operator has easy access and all connections can be made securely and safely. If possible, position the controller away from direct sunlight, particularly in hot weather.
2. Connect the AGC-3 power cable to a 120 VAC outlet (the power switch in the off position). **Caution:** The outlet must conform to local electric codes and regulations.
3. Connect and position the light stand using the Light stand outlet.
4. If used, connect the air gate to the Gate outlet using a standard 120 VAC plug. **Caution:** The wiring between the AGC-3 and the air gate must conform to local electric codes and regulations.

5. If used, connect the magnet(s) to the Accessories outlet (provided that your unit has the Accessories outlet configured for magnets, see the Specifications page)
6. If used, connect external speakers using the two Speakers jacks. If used, connect an external amplifier to the PA Amp jack. For more information regarding external audio components, see section 2.4.

2.3 Operating the AGC-3.

1. Turn the power switch on. The red light will illuminate.
2. If the gate is down, raise the gate by using the air gate reset switch (item 2 in figure 3). If using an up/down gate, it is sufficient to hold the switch for about one second. When an up only gate is used, maintain the switch until the gate is fully raised. (Also see section 2.1). **Caution:** Ensure that the gate is clear of riders before raising.
3. Use the start switch (item 5 in figure 3) to activate the voice commands. Set the volume control for the best quality voice.
4. If necessary, use the microphone and microphone activation switch (items 1 and 3 in figure 3) to direct the riders to the gate.
5. Use the start switch to start the riders. The first voice command is "**OK riders, set 'em up**" followed by a delay. The second voice command is "**On the gate**" followed by a second delay. The third voice command is "**Riders ready, watch the light**". On the word "watch" the red light stand light is turned on. At the word "light", the green light stand light is turned on. When the green light comes on, the gate will drop. Before the start of the light sequence, it is possible to reset the controller by using the start button a second time.
6. If there is a false start, use the horn switch (item 4 in figure 3) to recall the riders.
7. After the riders have departed, raise the gate for the next race.
8. Repeat steps 4 through 7.

2.4 Using external audio components.

Normally, the AGC-3's built-in speakers will be more than adequate. Even so, there are situations when it could be beneficial to use external speakers. These speakers are connected to the AGC-3 using 1/4 inch plugs. When the plug is inserted, the internal speaker is turned off. If two external speakers are used and positioned in close proximity, it is important that both have the same polarity. This is not a problem if the speakers are of the same type, but if they are different types, a simple test can be used to verify proper polarity:

Position the speakers side-by-side. Run the voice commands. If the sound is "thin", with little bass when compared to the internal speakers, it is likely that the wires in the plug will have to be switched. Re-test after switching wires to confirm a fuller sound.

Any external speaker should have a minimum impedance rating of 4 ohms and should be rated at a minimum of 25W of power.

When selecting an external speaker, it is important to find a high sensitivity model, preferably with a 4 ohm impedance rating.

To obtain more power than what is available from the internal amplifiers, it is possible to connect an external amplifier to the PA Amp jack. When an external amplifier is used, the front panel volume control will control the audio level at the jack. Connecting the amplifier will not turn off the internal speakers. To turn off the speakers, insert two 1/4 inch plugs into the Speakers jacks.

The maximum level at the PA Amp jack is approximately 1 Vrms. The minimum load should not be less than 10 kohms.

The AGC-3 controller has a built-in microphone for use by the starter. **It is not possible to connect an external microphone to the controller.**

3. Troubleshooting.

There are no user serviceable parts inside the AGC-3. Please consult the factory if you suspect internal problems.

The following list highlights some of the possible problems along with the appropriate corrective action:

1. *Loss of power in lightstand or magnet output:* Both lightstand and magnet outputs are protected by auto-reset fuses. If there is an overload on either output, that output will be turned off. Remove the lightstand or magnet plug and check for short circuits. The output will be turned on again after the fuse is reset (typically in a few minutes).
2. *Malfunctioning up/down air gate:* If the air gate is not functioning properly, it is helpful to know if the problem is in the air gate or in the AGC-3. To diagnose the problem, connect a load which can easily be monitored to the Gate outlet (120 V lamp, hair dryer, etc.). Operate the gate reset switch and note that the load is turned on (please note that there is a short delay before the switch is activated). Use the start switch and observe that the load is turned off on the green light. Ensure proper setting of SW3 (see section 2.1).
3. *Poor sound quality on the electronic horn:* If the sound of the horn is distorted, the front panel volume control or the internal horn volume control (item 1 in figure 4) may be set too high. If the sound of the electronic horn is too quiet or missing, the internal horn volume control may be set too low. If the tone of the horn is too low or too high, the internal horn tone control (item 2 in figure 4) may need adjustment.

4. *Poor sound quality on the voice:* If the voice is distorted, the front panel volume control may be set too high. Turn the volume control (item 3 in figure 1) counter-clockwise.
5. *Feedback when using the microphone:* If there is feedback when using the microphone, try to move away from the speakers. Use the microphone switch (item 1 in figure 3) only when talking.
6. *Voice commands not as expected:* If the voice commands appear to be non-standard or the pauses between commands are too long or short, the internal mode switches and rotary switches (see section 2.1) may have been changed. Please refer to the factory switch settings section on the Specifications page for proper settings.

4. Connector wiring.

The proper wiring of the light stand connector and the accessories connector is shown in Figure 5. Please note that the connectors are shown from the front.

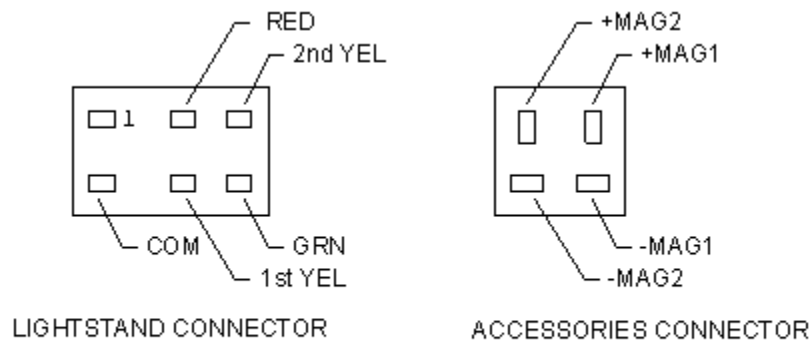

Figure 5.

Specifications.

Power: 120 VAC \pm 10%.

External speakers output: 4 ohms minimum, 25W minimum.

External PA amplifier output: 1 Vrms maximum, 10 kohm minimum

Accessories output: Dual 12 VDC magnet output, 4A/magnet maximum

Utility power output: 120 VAC/5 A unswitched

Gate output: 120 VAC

Lightstand output: 12 VDC, 1A/lamp, 4 lamps maximum

FACTORY SWITCH SETTINGS			
DIP-SWITCHES		ROTARY SWITCHES	
SW1	SW2	DELAY1	DELAY2
ON	OFF	C	7

Please note that there may have been changes in the switch settings after this unit was manufactured. Consult the factory or the league offices for the latest information.

[Back to Instructions Page](#)